

**f.a.l.**

# **SPARK 575**

## **Instruction Manual**

model:

PF 1309

SPARK 575

### **ATTENTION**

This instruction manual contains important information about the installation and use of the projector. Please read and follow these instruction carefully.

### **ATTENTION**

Always ensure that the power to the projector is disconnected before opening the projector or commencing any maintenance work.



# INDEX

01 – SAFE USAGE OF THE PROJECTOR .....	3
02 – INSTALLING THE PROJECTOR .....	3
03 – FITTING THE LAMP.....	4
04 – POWER SUPPLY - MAINS .....	5
05 – ZOOM AND FOCUS.....	5
06 – IRIS.....	5
07 – DIMMER / BLACK- OUT .....	6
08 – ACCESSORIES.....	6
09 – BALANCING THE PROJECTOR .....	7
10 – MAINTENANCE.....	7
11 – ELECTRICAL DIAGRAM.....	8
12 – TECHNICAL DATA.....	8

---

Please note that as part of F.A.L.'s ongoing commitment to continuous product development, specifications are subject to change without notice. Whilst every care is taken in the preparation of this manual F.A.L. reserves the right to change specifications in the course of product improvement. The publishers cannot be held responsible for the accuracy of the information herein, or any consequence arising from them.

## 01 – SAFE USAGE OF THE PROJECTOR

- ❖ Disconnect power before opening the projector.
- ❖ Do not attempt to dismantle and modify the projector.
- ❖ Do not allow contact with water or any other fluids, or metallic objects (IP 20).
- ❖ Do not install the projector in areas of high humidity.
- ❖  Not allowed to be mounted directly on inflammable surfaces.
- ❖ Keep at least 0.5m distance between the projector and adjacent inflammable surfaces.
- ❖ The lighting apparatus must be used only with its protective shield.
- ❖ The protective grill, lenses or ultraviolet filter must be changed if they are visibly damaged to the point at which their effectiveness is diminished, for example by becoming cracked or deeply scratched.
- ❖ The lamp must be replaced if it becomes damaged or deformed by heat.
- ❖  3 m  Keep at least 3m between the lamp and the illuminated surfaces.
- ❖ Avoid direct exposure to the light from the lamp. The light is harmful to the eye.
- ❖ Note:- The lamp reaches very high temperatures, allow at least 10 minutes for the lamp to cool completely before attempting to handle it.
- ❖ To ensure the reliability of the projector, it is recommended that the fans should be cleaned every 15 days. The lens, reflector and dichroic colour filters should also be regularly cleaned to maintain an optimum light output.

## 02 – INSTALLING THE PROJECTOR

The projector should be fixed on an appropriate stand which will remain stable on an incline of up to 15°. Always ensure that the stand or structure to which you are attaching the projector is secure and is able to support the weight of 26kg for each followspot. The projector should be fixed using the bracket (1). The projector bracket allows an angle adjustment of +55°/ -40° and, once positioned, the knob (2) should be firmly tightened.

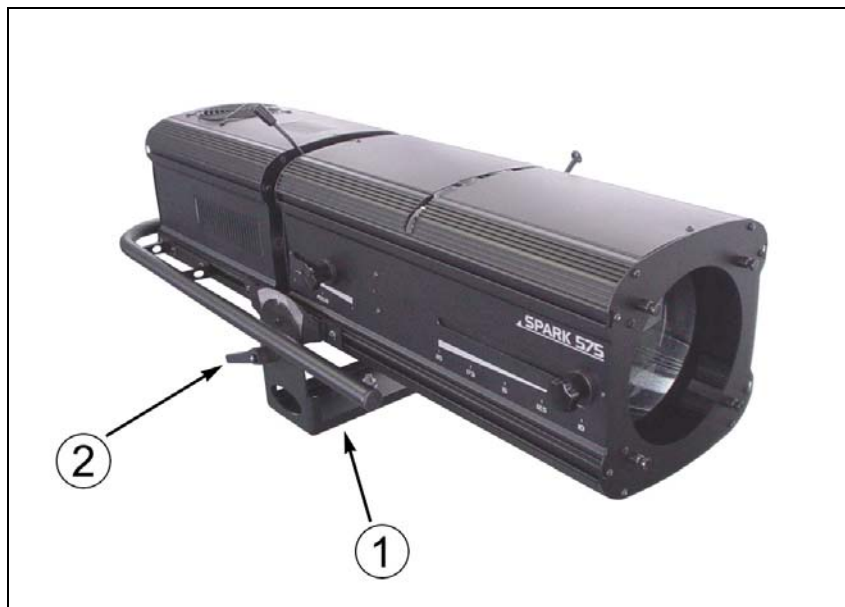

### 03 – FITTING THE LAMP

Open the lamp access hatch at the top of the projector by undoing the 2 bolts (3). Insert either an MSR 575 – MSD 575 lamp (Philips) or an HSD 575 – HSR 575 lamp (Osram) in the lamp holder as shown below.

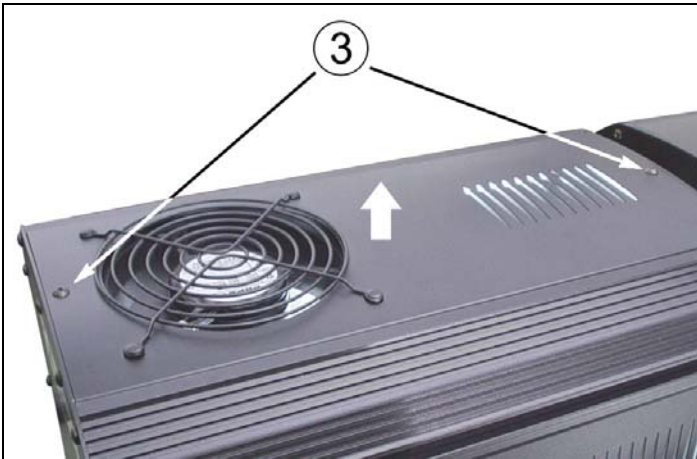

It will often be necessary to adjust the lamp alignment to obtain an even distribution of light within the beam. The seven screws (4, 5 and 6) may be gently turned to centre the lamp within the reflector.

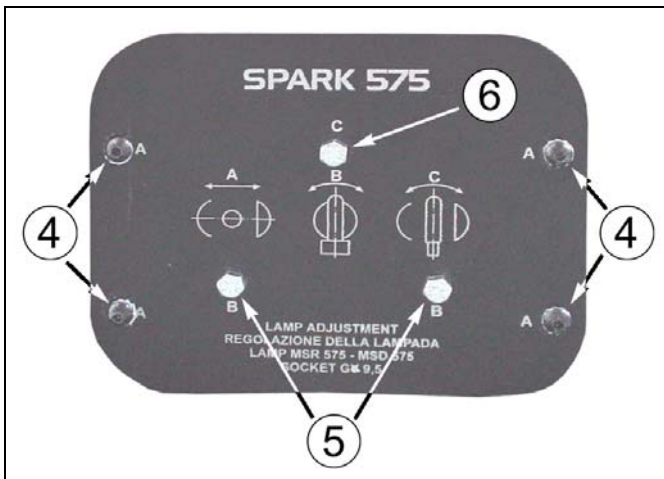

With the four screws labelled A (4) it is possible to move the lamp horizontally along the optical axis, with the two screws (5) it is possible to adjust horizontally the lamp from left to right, while the central screw (6) rotates the lamp vertically from the reflector to the condenser.

The projector should be switched on with the shutter open and the beam focused on a white surface to do this, it is also advisable to allow the lamp 5 minutes to come up to full brightness before starting to align it.

#### Note

The three screws will only need a small adjustment to centre the lamp, do not try to unscrew them completely. Read the rest of this manual and then come back to this section to align the lamp.

When inserting the lamp, please check that the lamp is not in contact with the condenser lens: never let the lamp touch the lens, in normal operation this may cause the explosion of both elements due to mechanical stress. Also, once aligned the lamp, turn the power off, let the lamp cool and then check again the distance between the lamp and the condenser lens.

These discharge lamps are high pressure lamps with external igniter. Care should always be taken when handling these lamps. If the glass is accidentally touched, follow the manufacturers instructions for cleaning the lamp before you use it, otherwise the lamp life may be significantly reduced. Always read the manufacturers "Instructions for use" enclosed with the lamp.

## 04 – POWER SUPPLY - MAINS

In order to connect the device to the mains supply, you have to install a proper plug to the power cable (7) located on the rear of the followspot. Use the plug to connect the projector to the mains power, paying attention to the voltage and frequency marked on the label attached to the projector. The blue wire should be connected to the terminal marked N (neutral), the brown wire to the live (L) and the yellow and green wire to the earth. The projector can be switched on by pressing the green button (8) located on the rear of the projector.

L = Brown

E = Yellow / Green

N = Blue



### IMPORTANT

It is essential that each projector is correctly earthed and that electrical installation conforms to all relevant standards. Power consumption of the Spark 575 is 800VA.

## 05 – ZOOM AND FOCUS

Zoom and focus of the light beam are obtained using the 2 knobs (9 - 10) located on the right side of the projector. The beam spread can be adjusted from 10° (handles apart) to 20° (handles together).

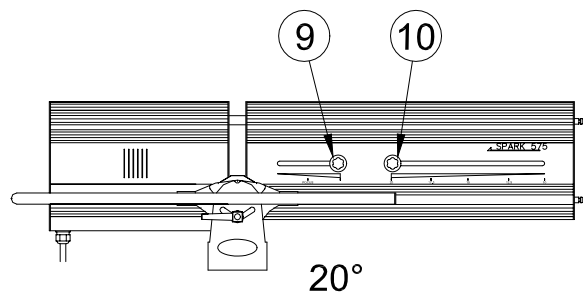
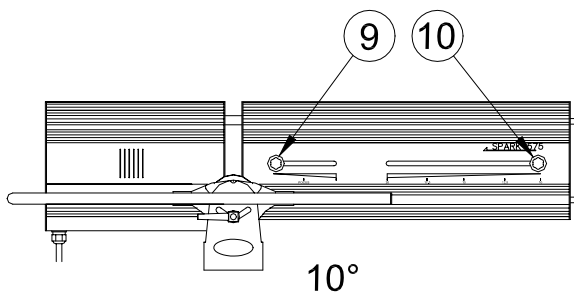

## 06 – IRIS

The iris is adjusted by moving the lever (11) which allows a beam reduction up to 2°. Insert the Iris in the slot (12) on the upper side of the projector.

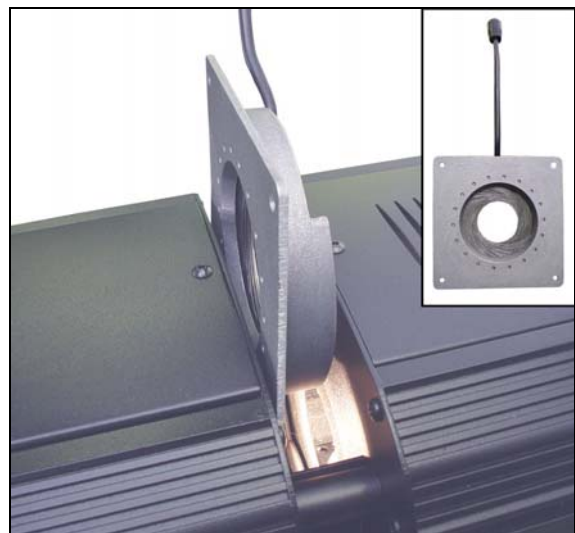
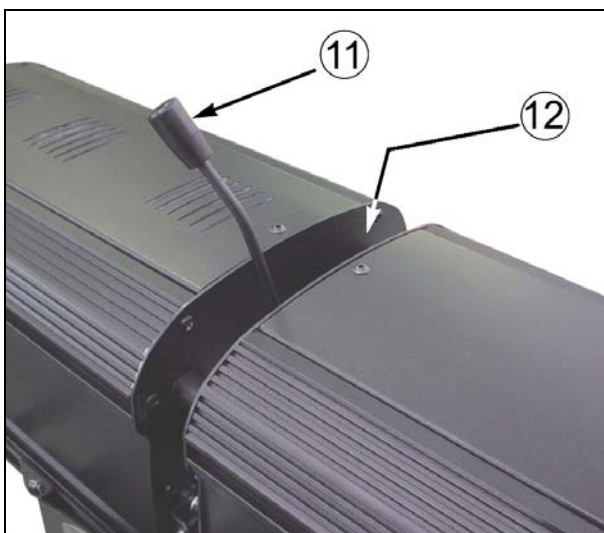

## 07 – DIMMER / BLACK- OUT

The lever (13) on the upper side of the projector allows you to dim light beam and to black out the projector. The beam brightness can be adjusted from 0% (black-out) to 100% (maximum brightness) by moving the lever (13) from left to right.



## 08 – ACCESSORIES

### GOBO HOLDER (code 819PF)



The Spark 575 can accept an adjustable gobo holder for standard 66mm diameter gobos. The holder should be inserted into the slot (12) after removing the iris.

### COLOUR-CHANGER (code 1309CC)

The followspot has a colour changer (14) which fits onto the four pegs (15) and once positioned should be fixed with the security pivot (16): loosen the knob (17), slide the pivot out from the pipe and tighten the knob to fix it.

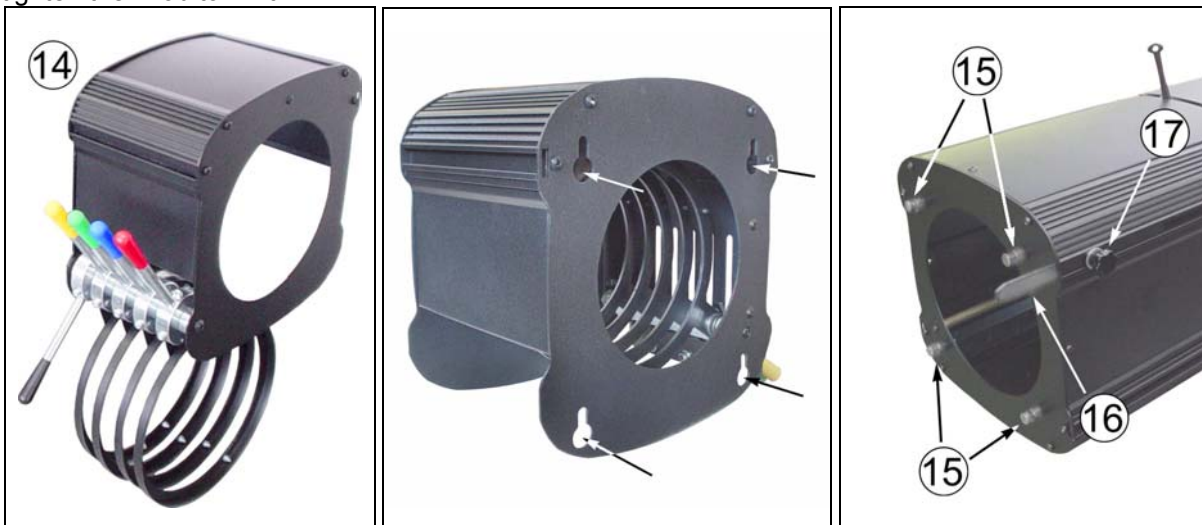

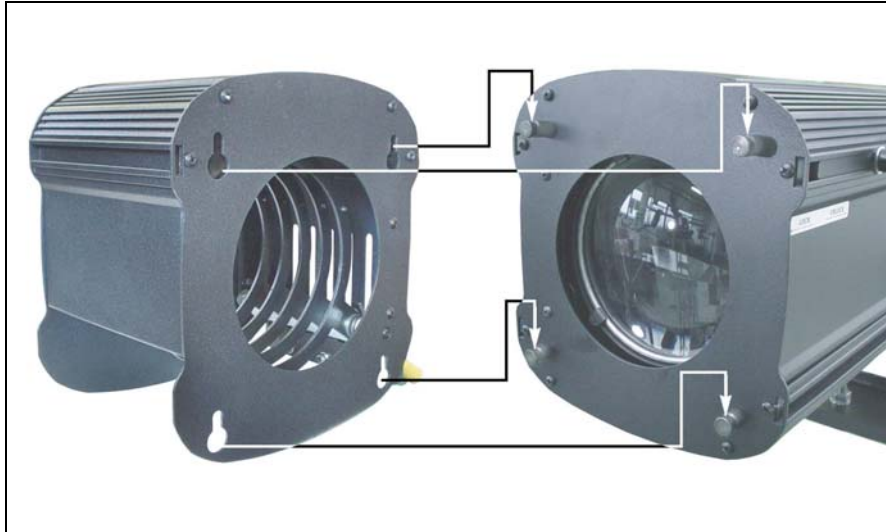

Insert the 96mm diameter colour filters in their appropriate filter frames. Place the colours in the beam by using the handles. Pull down one lever to select the desired colour (It is recommended that only filters with a high temperature capacity are used).

### 09 – BALANCING THE PROJECTOR

If you fit the colour changer, you have to balance the projector, so that the projector still remain horizontal and will not tilt down due to the additional weight.

Loosen the four screws (18) located on both sides of the yoke and move back the projector pipe, until you reach the equilibrium. Then tighten the screws (18).

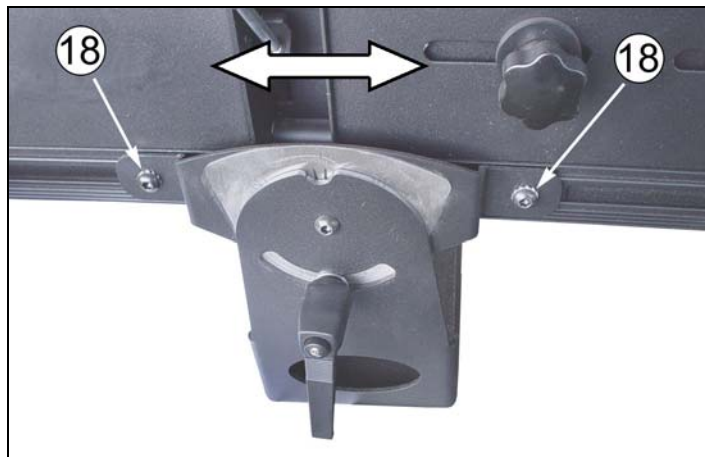

### 10 – MAINTENANCE

If the projector's lenses become damaged or broken, they should be replaced.

If the lamp becomes damaged or deformed in any way it must be replaced.

If the light from the lamp appears dim this would normally indicate that it is reaching the end of its life and it should be changed at once, old lamps run to the extremity of their life can explode.

If the projector does not function, check the fuse on the bottom side of the projector, it should only be replaced by fuses of the same value as that marked on the panel beside the fuse holder.

The Spark 575 also has a thermal protection device that will switch off the projector in case of overheating, should this operate, check that the fan is not blocked, and if it is dirty clean it before switching on the projector again.

Check that the fan is operational, if not call a qualified technician.

## 11 – ELECTRICAL DIAGRAM

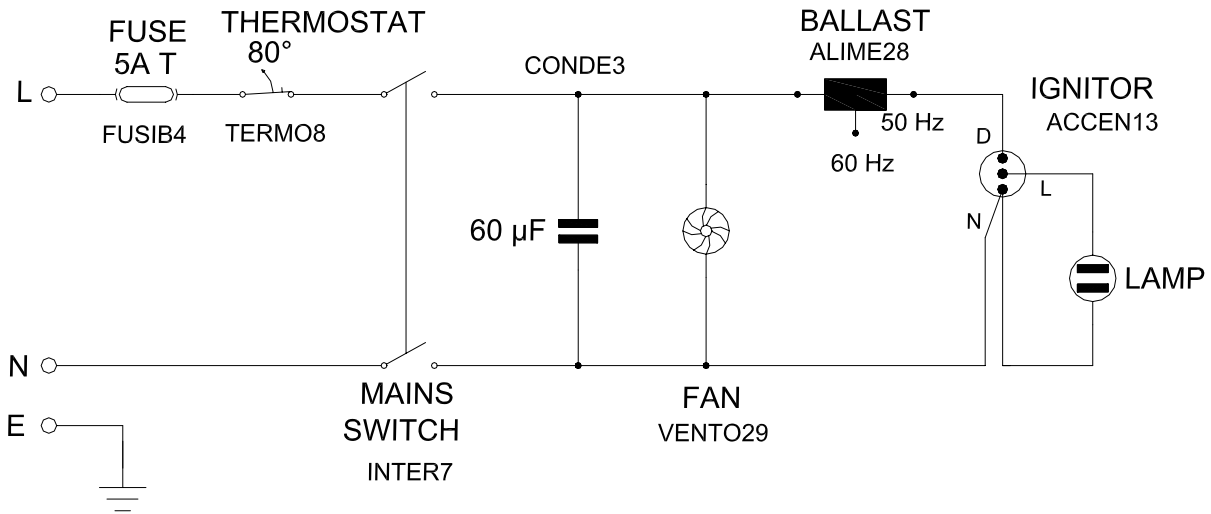

## 12 – TECHNICAL DATA

<b>POWER SUPPLY:</b>	230V 50Hz (60Hz to order).
<b>POWER CONSUMPTION:</b>	800VA at 230V.
<b>LAMP:</b>	MSR 575, MSR 575/2, HSR 575/60, HSR 575/72, HSD 575, MSD 575 discharge lamp. Colour Temperature 5600K. Socket GX 9.5, life 2000 hours (manufacturer ratings).
<b>DIVERGENCE:</b>	10° to 20°.
<b>BLACKOUT:</b>	Blackout shutter provided.
<b>IRIS:</b>	Interchangeable iris included.
<b>DIMMER:</b>	Variable dimmer from 0% to 100%.
<b>COLOURS:</b>	Optional colour changer for 5 dichroic filters or gel (code 1309CC).
<b>GOBO HOLDER:</b>	Optional gobo holder for 66mm diameter M-size gobo (code 819PF).
<b>COOLING:</b>	Forced cooling via low noise axial fan.
<b>HOUSING:</b>	Extruded aluminium and steel plate. Metal parts have epoxy powder paint finish. Easy access to lamp and main components. Protection: IP20.
<b>OPERATING CONDITIONS:</b>	Projector may be tilted +55°/ -40° from the horizontal.
<b>DIMENSIONS:</b>	910mm L x 320mm W x 420mm H (included bracket). Weight 26kg.
<b>REFERENCE NORM:</b>	CE