

f.a.l.

COLOURTRONIC 1200

INSTRUCTION MANUAL

model:

PF 3008 COLOURTRONIC HMI 1200W

IMPORTANT

This instruction manual contains important information about the installation and use of this projector. Please read and follow these instructions carefully.

IMPORTANT

Always ensure that the power to the projector is disconnected before opening the projector or commencing any maintenance work.

INDEX

SECTION	PAGE.
01 - INSTALLING THE PROJECTOR	3
02 - FITTING THE LAMP	3
03 - POWER SUPPLY - MAINS	4
04 - CONTROL CONNECTIONS	4
05 - PROJECTOR ADDRESSES	5
06 - SETUP OPTIONS	5
07 - DMX CHANNEL FUNCTIONS	6
08 - MAINTENANCE	8
09 - KEEPING THE PROJECTOR CLEAN	8
10 - WARNING	8
11 - TROUBLESHOOTING	8
12 - ELECTRICAL DIAGRAM	9
13 - TECHNICAL SPECIFICATIONS	10

Please note that as part of F.A.L.'s ongoing commitment to continuous product development, specifications are subject to change without notice. Whilst every care is taken in the preparation of this manual F.A.L. reserves the right to change specifications in the course of product improvement. The publishers cannot be held responsible for the accuracy of the information herein, or any consequence arising from them.

01 - INSTALLING THE PROJECTOR

The projector should be mounted via its bracket (1) using at least two M10 size screws. Always ensure that the structure to which you are attaching the projector is secure and is able to support a weight of 33Kg. For each Colourtronic. The projector bracket allows an angle adjustment of +/- 45° and, once positioned, the knob (2) should be firmly tightened. For safety the projector should have a secondary fixing with a safety chain attached to eye (3).

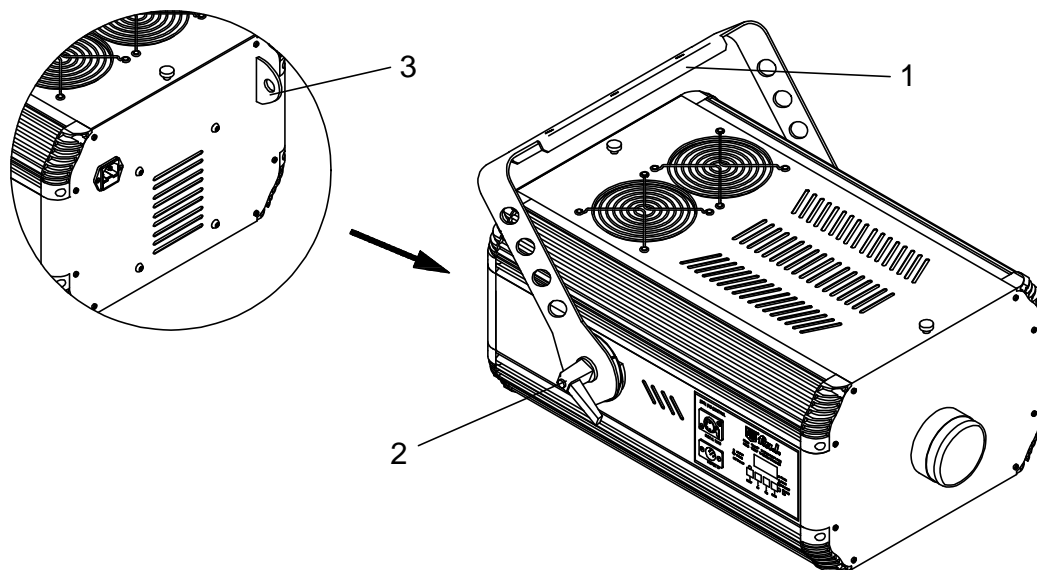

02 - FITTING THE LAMP

02.01 - The lamp access hatch is released by undoing the fastening screws (4), the hatch may then be lifted upwards to open. Insert the HMI 1200 lamp, taking care not to touch the glass part of the lamp. If the glass is accidentally touched, follow the manufacturers instructions for cleaning the lamp before you use it, otherwise the lamp life may be significantly reduced. Once the lamp has been inserted make sure the glass pip (P) on the bulb is facing upwards as shown in fig. A below, this ensures uniform light distribution, then tighten the two knurled nuts on the lamp. Close and fasten the lamp access hatch. Care should always be taken when handling these lamps. Always read the manufacturers "Instructions for use" enclosed with the lamp.

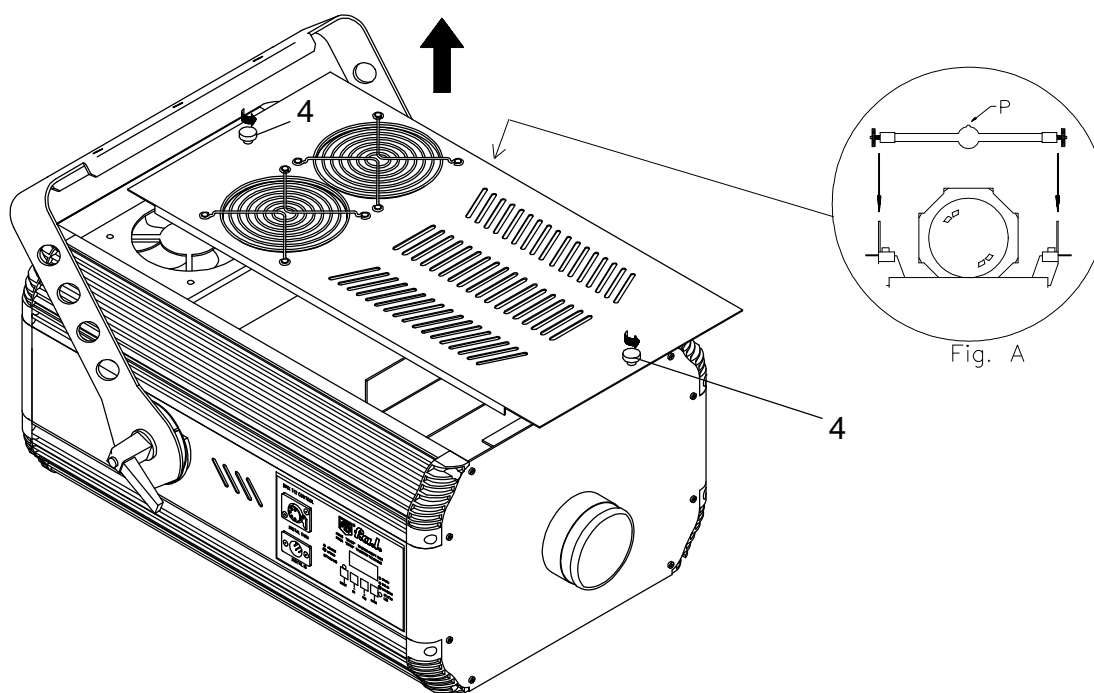

03 - POWER SUPPLY - MAINS

Use the plug provided to connect the mains power to the projector paying attention to the voltage and frequency marked on the back panel of the projector. It is recommended that each projector is supplied separately so that they may be individually switched on and off.

IMPORTANT

It is essential that each projector is correctly earthed and that electrical installation conforms to all relevant standards. Power consumption of the Colourtronic is 1900 VA.

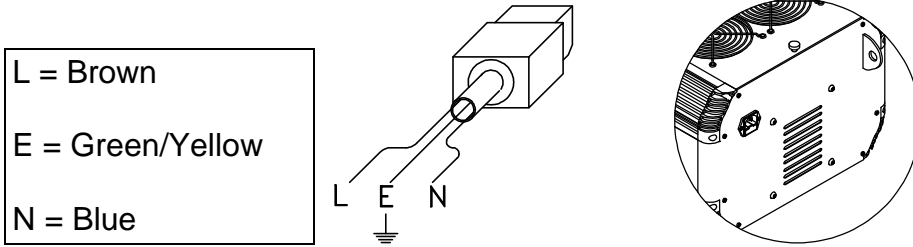

WATCHDOG SYSTEM

When the projector is switched on the electronics perform a reset, this function moves rotates the internal wheels thus allowing the microprocessor control system to register the positions of all motors under its control. When the lamp strikes and "fires up" it can create a certain amount of electrical noise within the projector that has the potential to disturb the microprocessor. The Colourtronic is fitted with an electronic watchdog system that monitors the microprocessor and will initiate a reset if the functioning of the microprocessor has been disturbed. This system ensures that the reset is performed successfully and that once completed the projector is ready to receive control instructions and operate without problem.

04 - CONTROL CONNECTIONS

The Colourtronic can accept digital control signals in DMX512 (1990) format. Connection between controller and projector and between one projector and another must be made with 2 core screened cable, with each core having at least a 0,5mm diameter. Connection to and from the projector is via cannon 5 pin XLR plugs and sockets which are included with the projector. The XLR's are connected as shown in the table below. Note, care should be taken to ensure that none of the connections touch the body of the plug or each other. The body of the plug is not connected in any way. Connect the control signal to the socket on the top panel marked DIGITAL IN and then from the socket marked DIGITAL THRU to the DIGITAL IN socket of the next projector. The Status led indicates the status of the DMX signal. If the led is flashing the DMX signal is not correct, if the led is off there is no DMX signal arriving, and if the led is lit continuously this means that the DMX signal is good.

DMX 512 CONTROL

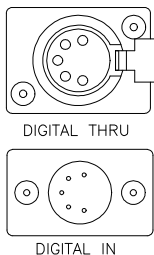

PIN	DMX 512 FUNZIONE
1	GND
2	DATA -
3	DATA+
4	N.C.
5	N.C.
N.C. = No Connection	

DMX TERMINATION

For all installations it is recommended practice to use a DMX terminator, this assists in preventing corruption of the digital control signal by electrical noise etc. The DMX terminator is simply an XLR connector with a 120Ω (ohm) resistor connected across pins 2 and 3, which is then plugged into the DIGITAL THRU socket on the last projector in the chain. The connections are illustrated below.

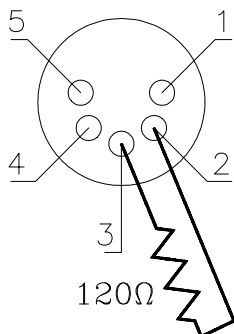

DMX TERMINATOR CONNECTION

Connect a 120Ω (OHM) resistor across pins 2 and 3 in an XLR plug and insert into the Digital Thru socket on the last unit in the chain.

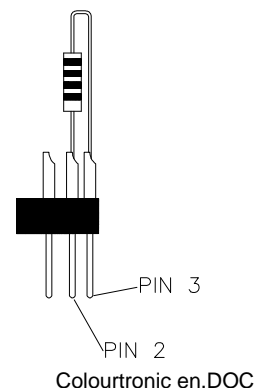

05 - PROJECTOR ADDRESSES

Each Colourtronic must be given a digital start address number so that the correct projector responds to the correct control signals. This digital start address is the channel number from which the projector starts to "listen" to the digital control information being sent out from the controller. The Colourtronic uses five (5) digital control channels. The digital start address is assigned by setting the correct number on the display on the side panel of the projector. Press the SELECT button and the Setting led will light red. Use the + and - buttons to set the required start address in the display then confirm by pressing ENTER twice. For example, projector 1 would have a start address of 1, projector 2 would have an address of 6, and projector 3 an address of 11 etc.

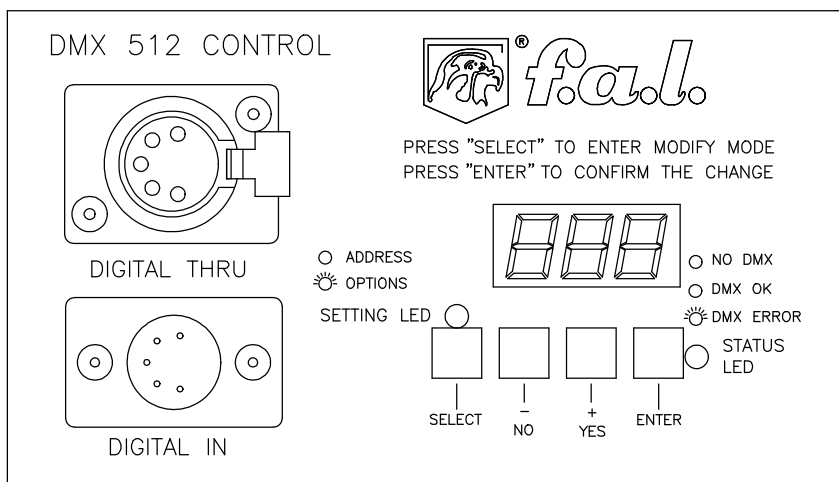

06 - SETUP OPTIONS

There are 6 set-up options available on the Colourtronic. The SELECT button will page through the options from 1 to 8, (options 4 and 5 are reserved) if you have just set the address you will be at option 1, otherwise pressing the SELECT button twice will bring you to option 1 and the main display will show 1 no, or 1 Y, depending on what was previously set. The SETTING led will flash red. Pressing the SELECT button again will take you to option 2, then 3 and so on. **If you change an option setting you must confirm the new setting by pressing ENTER twice.**

FIXED COLOUR POSITIONS

If option 1 is set to Y (= yes) the colour wheel will only stop at full colour positions and can not be made to stop between colours for a split colour effect. Confirm your selection.

FIXED BI-COLOUR POSITIONS

If option 2 is set to yes (**2 Y**) the colour wheel will only stop on full or half colour positions, it will not stop at intermediate positions. For continuously variable colours options 1 and 2 must be set to no, (**1 no and 2 no**).

SHUTTER ON COLOUR CHANGE

Operating on exactly the same principal as the previous option (shutter on gobo change), selecting yes to option 3 (**3 Y**) will cause the shutter to close, blacking out the beam each time the colour wheel is rotated to a new position to show a new colour. In the no position (**3 no**) the beam is not blacked out and remains visible as the colour wheel rotates to its new position. Confirm your selection.

Options 4 and 5 are reserved for future expansion and are not currently in use.

RESET

With option 6 set to off (6 N) the soft reset function of the projector is maintained on DMX channel 1, if a value between 4 and 6 is sent on channel 1 the projector will make a reset. If option 6 is set to on (6 Y) the soft reset function is moved to DMX channel 5 with a value of between 244 and 255.

TEST 1 (Motor test)

Activation of option 7 is used to check that all motors are functioning correctly. This function will only operate if there is no DMX signal connected.

TEST 2 (Zero positions)

Activating this function (**8 Y**) places all motors in their zero position and is used for factory adjustments. The projector will **NOT** respond to any control signals while this option is on (y).

07 - DMX CHANNEL FUNCTIONS

Channel	Function
1	Colour Wheel 1
2	Colour Wheel 2
3	Effects
4	Shutter, Strobe, Dimmer
5	Operating Mode Selection

The Colourtronic has two (2) Operating Modes (Mode 1 and Mode 2) and these are selected via DMX channel 5. These Modes determine both how the 2 colour wheels function and how the DMX control values affect them.

MODE 1

If DMX channel 5 is kept at a value between 0 and 89 DMX channels 1 and 2 will function as follows:-

CHANNEL 1 - COLOUR WHEEL 1

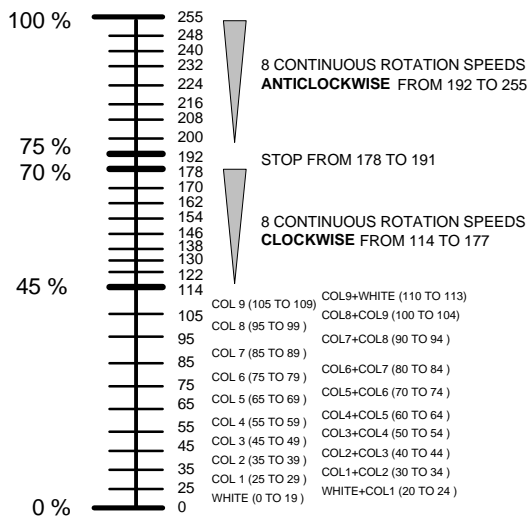

Control values for **Colour Wheel 1**, in DMX units.

CHANNEL 2 - COLOUR WHEEL 2

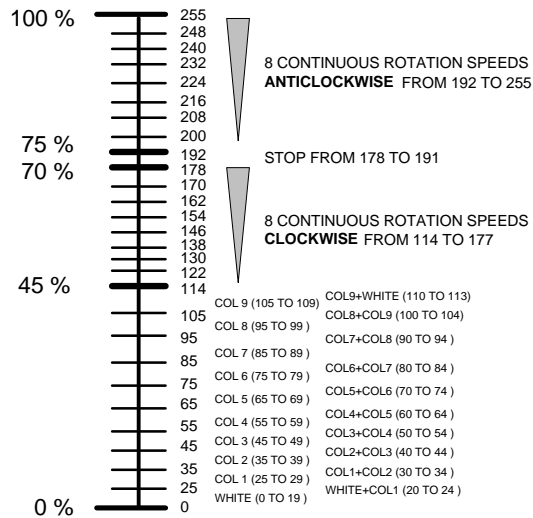

Control values for **Colour Wheel 2**, in DMX units.

REMOTE REQUESTED RESET - SOFT RESET

If the DMX value sent on channel 1 stays in the range from 4 to 6 for more than 6 seconds, the projector will start a reset sequence (Remote Requested Reset). The electronics are re-started and all motors moved to their home positions exactly as they do when the power is first switched on but the lamp is not switched off in this sequence, although the beam will be blacked out. See also Option 6.

CHANNEL 3 - EFFECTS WHEEL

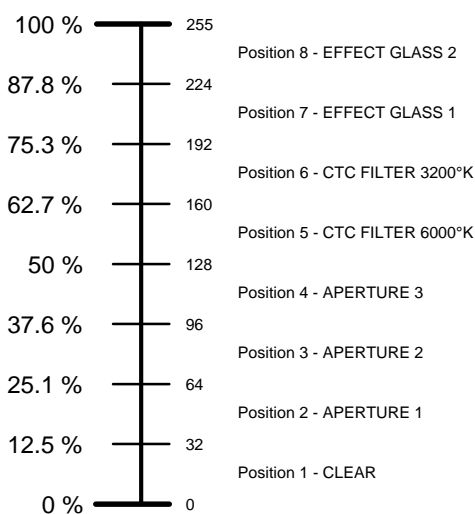

Control values for **Effects Wheel**, in DMX units.

CHANNEL 4 - SHUTTER, STROBE

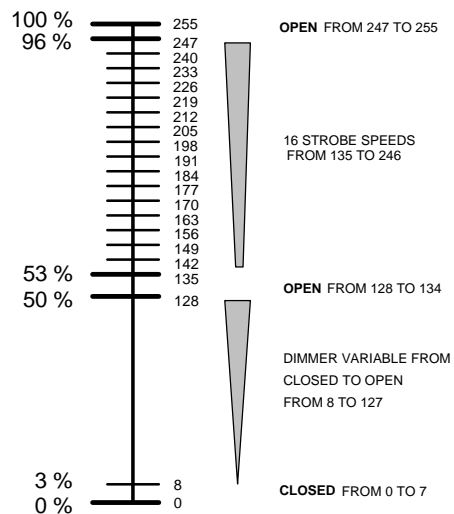

Control values for **Shutter/Strobe/Dimmer**, in DMX units.

CHANNEL 5 - OPERATING MODE

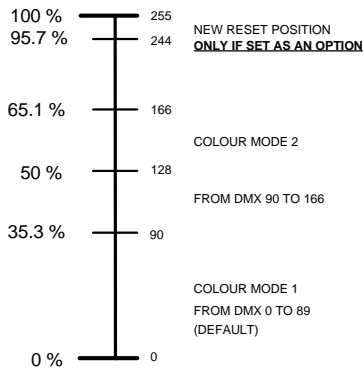

MODE 2

If DMX channel 5 is sent a value between 90 and 165 the projector functions in Colour Mode 2 and the following values and functions now apply to channels 1 and 2 :

CHANNEL 1 - INDIVIDUAL COLOURS

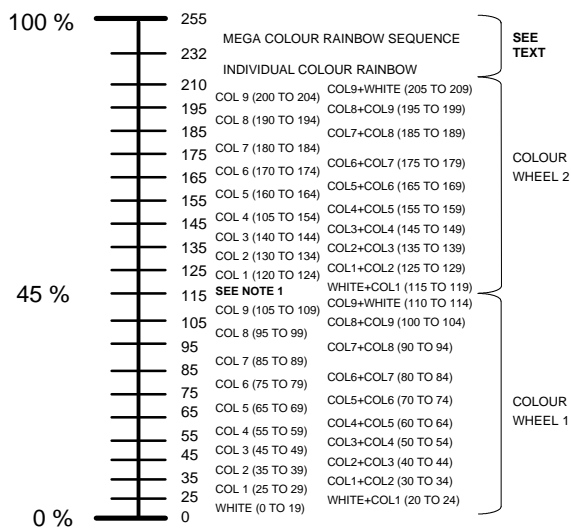

CHANNEL 2 - MIXED COLOURS

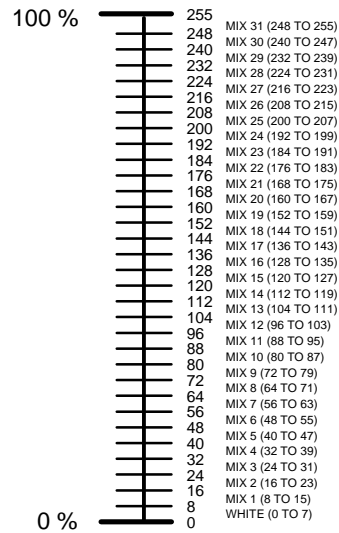

In Colour Mode 2, channel 1 allows selection of each individual colour on both colour wheels and channel 2 allows quick selection of all available mixed colour combinations Channel 2 has priority over channel 1, if channel 2 has a value other than zero channel 1 will not select the individual colours.

NOTE 1 With Option 1 set on (1 Y) - fixed colours only - the values for channel 1 are 105 - 114 = colour 9 wheel 1, 115 - 119 = white, 120 - 130 = colour 1 wheel 2.

In Colour Mode 2, if channel 1 is set to between 210 and 231 the projector performs an Individual Colour Rainbow effect. If channel 1 is set to between 232 and 255 the projector will perform a mega rainbow sequence that also includes all mixed colours. In both cases Channel 2 becomes the speed control for the sequences. This is only in Colour Mode 2 operation (channel 5 between 90 and 165).

CHANNEL 2 - SPEED

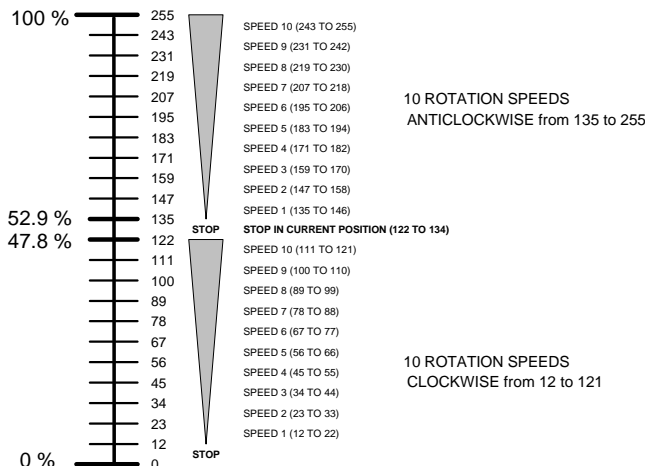

08 - MAINTENANCE

If the projector lens becomes damaged or broken it should be replaced. If the lamp becomes damaged or deformed in any way it must be replaced. If the light from the lamp appears dim this would normally indicate that it is reaching the end of its life and it should be changed at once, old lamps run to the extremity of their life can explode. If the projector does not function, check the fuses on the back panel of the projector, they should only be replaced by fuses of the same value as that marked on the back panel beside the fuse holder. On the electronics card (pcb) inside the projector is a fuse rated at 4A F, should this be damaged call a qualified technician before replacement. The Colourtronic also has a thermal protection device that will switch off the projector in case of overheating, should this operate, check that the fan is not blocked, and if it is dirty clean it before switching on the projector again. Check that the fan is operational, if not call a qualified technician.

09 - KEEPING THE PROJECTOR CLEAN

To ensure the reliability of the projector it should be kept clean. It is recommended that the fan should be cleaned every 15 days. The lens, and dichroic colour filters should also be regularly cleaned to maintain an optimum light output. Do NOT use any type of solvent on the dichroic colour filters.

10 - WARNING

- * Do not attempt to dismantle and modify the projector.
- * Do not allow contact with water or any other fluids, or metallic objects (IP 20)
- * Do not install the projector in areas of high humidity
- * Do not project the beam onto inflammable surfaces, minimum distance is 5 m. ⚠ 5 m ⚠
- * Keep at least 0,5m distance between the projector and adjacent inflammable surfaces.
- * Avoid direct exposure to the light from the lamp. The light is harmful to the eye.
- * Note :- The lamp reaches very high temperatures, allow at least 15 minutes for the lamp to cool completely before attempting to handle it.

11 - TROUBLESHOOTING

PROBLEM	POSSIBLE SOLUTION
The projector does not start	Check the fuses on the back panel
The lamp comes on but the projector does not respond to the controller	Check the digital start address (section 5) and check the wiring of the control cable (section 4)
The projector only functions intermittently	Check the fan is working and not dirty
The projected image appears to have a halo	Check the lamp is installed correctly (section 2)
The beam appears dim	The lamp may be at the end of its life and should be replaced. Check the optics are clean

Any other maintenance should only be performed by a qualified person.

12 - ELECTRICAL DIAGRAM

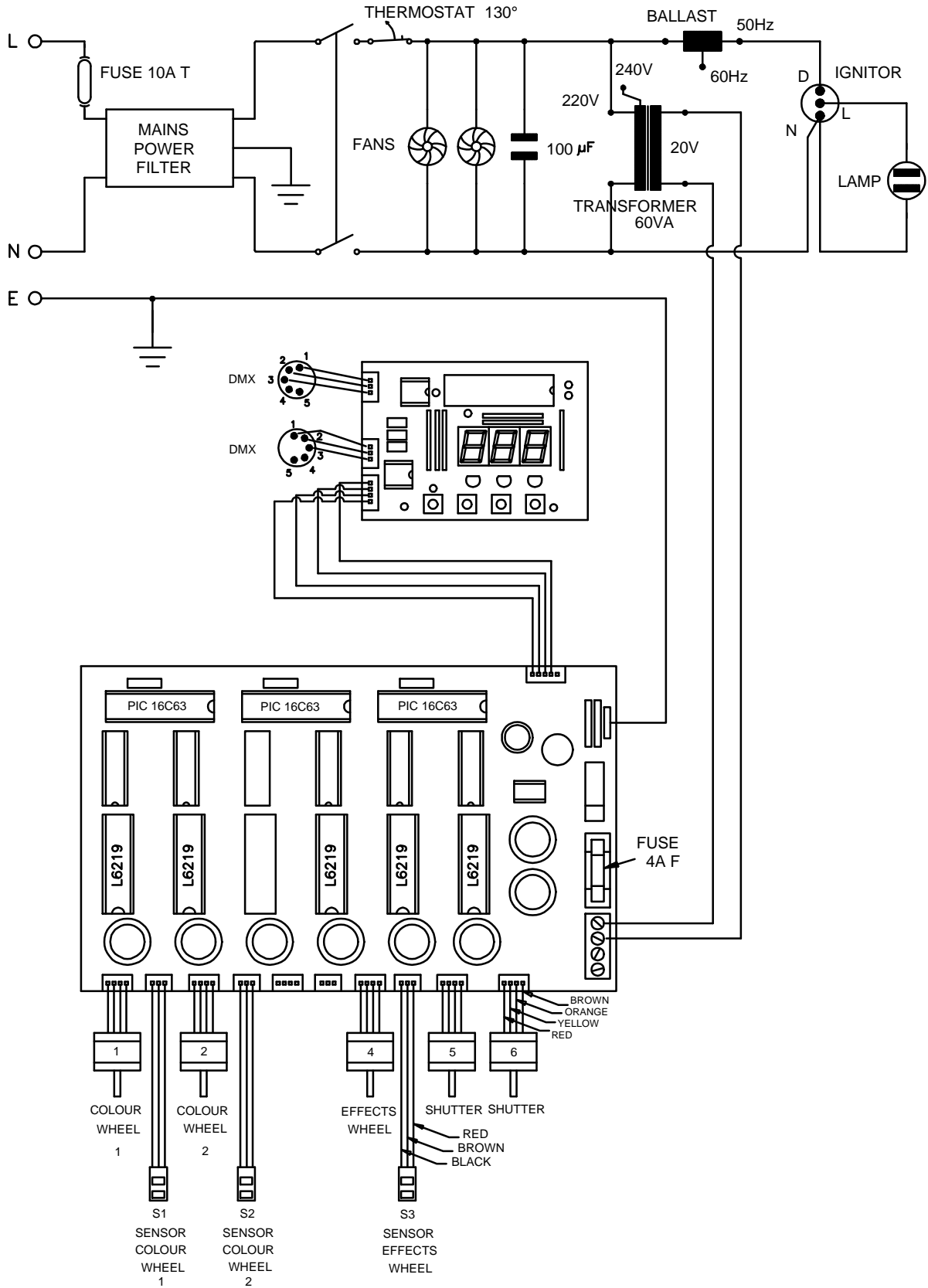

13 - TECHNICAL SPECIFICATIONS

POWER SUPPLY

230V 50Hz (or 60Hz to order).

POWER CONSUMPTION

1900VA at 230V.

LAMP

HMI 1200 W/GS discharge lamp.
Colour temperature 5600°K.
Socket Sfc 15,5-6.
Life 750 hours (manufacturers rating).

COLOURS

18 Dichroic colour filters + white. Colours mounted on 2 wheels providing 31 colour combinations. Continuous variable speed rotation of either or both colour wheels to produce rainbow effect.

C.T.C. FILTERS

2 Colour temperature correction filters, 3200°K and 6000°K.

EFFECTS

2 Effects glass 3D effects filters.

SHUTTER, STROBE, DIMMER

Fast shutter provides blackout and strobe effect variable between 1 and 7 flashes per second. Also smooth dimming.

MOTORS

5 stepper motors controlled via internal microprocessor.

CONTROL

Digital : DMX512 - 5 Channels.

HOUSING

In extruded aluminium with epoxy powder paint finish.
Easy access to lamp and main components.

DIMENSIONS

570mm. Long, x 470mm. Wide, x 246mm. High (380mm. inc. bracket).
Weight 33Kg.

