

f.a.l.

COLOUR DANCE HALOGEN LAMP

Instruction Manual

model:

PF 957 COLOUR DANCE – Halogen lamp

ATTENTION

This instruction manual contains important information about the installation and use of the projector. Please read and follow these instructions carefully.

ATTENTION



Always ensure that the power to the projector is disconnected before opening the projector or commencing any maintenance work.

INDEX

01 – SAFE USAGE OF THE PROJECTOR	3
02 - INSTALLING THE PROJECTOR.....	3
03 - FITTING THE LAMP.....	4
04 - POWER SUPPLY - MAINS	4
05 - FUNCTIONS	4
06 - CONTROL CONNECTIONS.....	5
07 - PROJECTOR ADDRESSES.....	5
08 – AUTOMATIC MODE.....	6
09 – DMX CHANNELS	6
10 – FOCUS	7
11 – MAINTENANCE	7
12 – KEEPING THE PROJECTOR CLEAN	7
13 – TROUBLESHOOTING.....	7
14 – ELECTRICAL DIAGRAM.....	8
15 – TECHNICAL DATA.....	9

Please note that as part of F.A.L.'s ongoing commitment to continuous product development, specifications are subject to change without notice. Whilst every care is taken in the preparation of this manual F.A.L. reserves the right to change specifications in the course of product improvement. The publishers cannot be held responsible for the accuracy of the information herein, or any consequence arising from them.

01 – SAFE USAGE OF THE PROJECTOR

- ✓ Do not attempt to dismantle and modify the projector.
- ✓ Do not allow contact with water or any other fluids, or metallic objects (IP 20).
- ✓ Do not install the projector in areas of high humidity.
- ✓  Not allowed to be mounted directly on inflammable surfaces.
- ✓ Keep at least 0.5m distance between the projector and adjacent inflammable surfaces.
- ✓ The lighting apparatus must be used complete with its protective grill and/or front lens.
- ✓ Protective grill, lenses, U.V. filters should be replaced if they are visibly damaged to the point at which their effectiveness is diminished, for example by becoming cracked or deeply scratched.
- ✓ The lamp must be replaced if it becomes damaged or deformed by heat.
- ✓  3 m  Keep at least 3m between the lamp and the illuminated surfaces.
- ✓ Avoid direct exposure to the light from the lamp. The light is harmful to the eye.
- ✓ Note:- The lamp reaches very high temperatures, allow at least 15 minutes for the lamp to cool completely before attempting to handle it.
- ✓ To ensure the reliability of the projector, it is recommended that the fans should be cleaned every 15 days. The lens, reflector and dichroic colour filters should also be regularly cleaned to maintain an optimum light output. In locations such as discotheques the objective lens should be cleaned every week as smoke fluid can condense on it and very quickly reduce the light output.

02 - INSTALLING THE PROJECTOR

The projector should be mounted via its bracket (1) using 2 M10 size bolts. Always ensure that the structure to which you are attaching the projector is secure and is able to support a weight of 7kg for each Colour Dance.

The projector bracket allows an angle adjustment of +/- 85° and, once positioned, the knob (2) should be firmly tightened.

For safety the projector should have a secondary fixing with a safety chain in the relevant fixing ring.

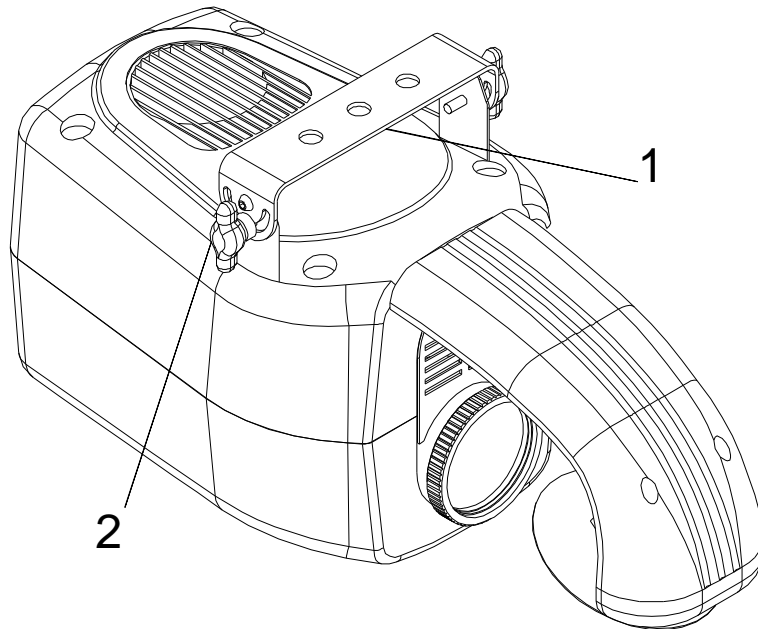

03 - FITTING THE LAMP

Open the lamp access hatch at the back of the projector by undoing the two knurled nuts (3). Unscrew the lamp holder as shown below, tilt lamp holder sideways to facilitate insertion of the EVC/FGX 250W 24V lamp. Care should always be taken when handling the lamps. Always read the manufacturers "Instructions for use" enclosed with the lamp.

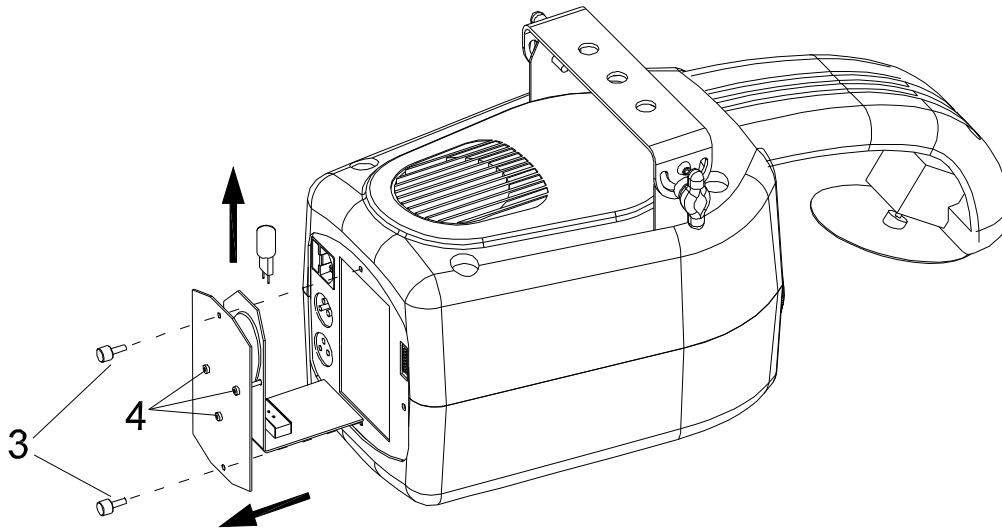

Then close the lamp access again. When the projector is switched on, align the lamp using the 3 screws (4) on the back to center the hot spot and give a uniform beam.

04 - POWER SUPPLY - MAINS

Use the plug provided to connect the mains power to the projector paying attention to the voltage and frequency marked on the projector. It is recommended that each projector is supplied separately so that they may be individually switched on and off.

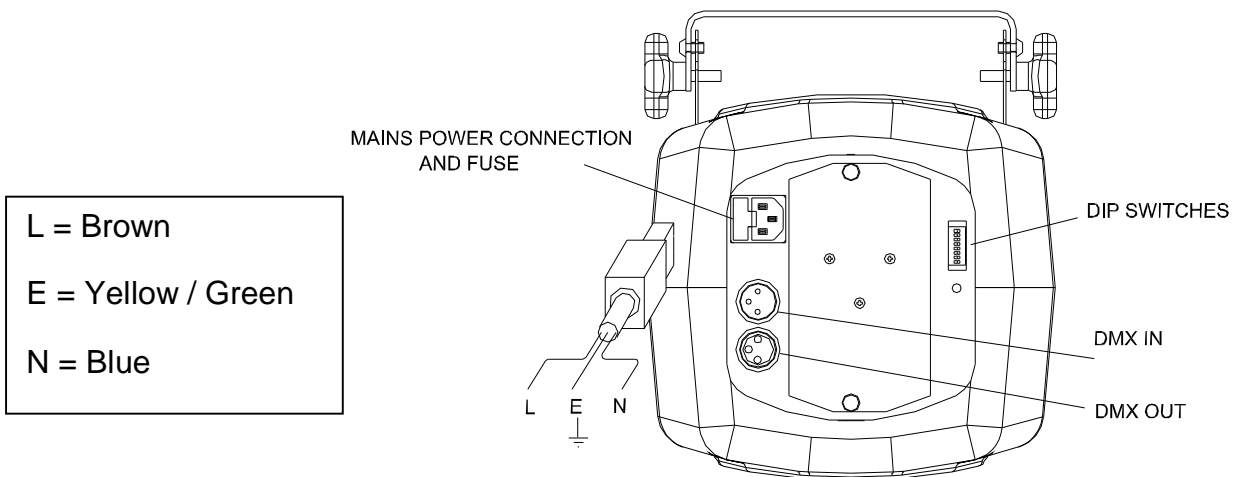

IMPORTANT

It is essential that each projector is correctly earthed and that electrical installation conforms to all relevant standards. Power consumption of the Colour Dance halogen is 280VA.

05 - FUNCTIONS

The Colour Dance can function in automatic sound activated mode as a Master or Slave unit, or via normal control with DMX512.

The Colour Dance projects 8 coloured gobos + white and blackout reflected via the rotating front mirror.

06 - CONTROL CONNECTIONS

The Colour Dance can accept digital control signals in DMX512 (1990) format. Connection between controller and projector and between one projector and another must be made with 2 core screened cable, with each core having at least a 0.5mm² cross section. Connection to and from the projector is via cannon 3 pin XLR plugs and sockets which are included with the projector. The XLR's are connected as shown in the table below. Note, care should be taken to ensure that none of the connections touch the body of the plug or each other. The body of the plug is not connected in any way. Connect the control signal to the socket on the back panel marked DMX IN and then from the socket marked DMX OUT to the DMX IN socket of the next projector.

When a DMX 512 signal is received the LED located near the dip-switch will flash constantly. When not receiving a DMX signal (or if set in Master Mode) the LED will be off.

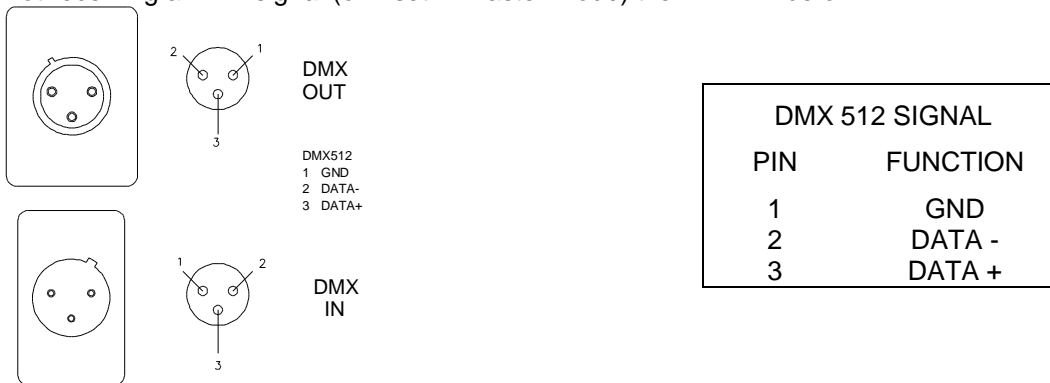

DMX TERMINATION

For all installations it is recommended practice to use a DMX terminator, this assists in preventing corruption of the digital control signal by electrical noise etc. The DMX terminator is simply an XLR connector with a 120Ω (ohm) resistor connected across pins 2 and 3, which is then plugged into the DMX OUT socket on the last projector in the chain. The connections are illustrated below.

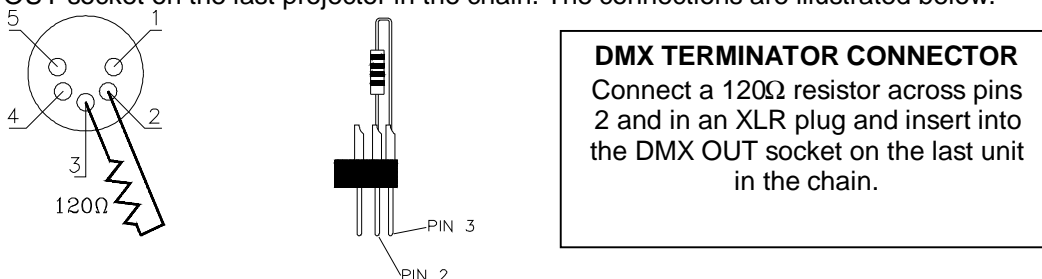

07 - PROJECTOR ADDRESSES

The Colour Dance halogen uses 3 digital control channels. Each Colour Dance must be given a digital start address number so that the correct projector responds to the correct control signals. This digital start address is the channel number from which the projector starts to "listen" to the digital control information being sent out from the controller. The digital start address is assigned by setting the correct number on the 9 DIP switches on the back panel of the projector (for example projector 1 address 1, projector 2 address 4, projector 3 address 7, etc.).

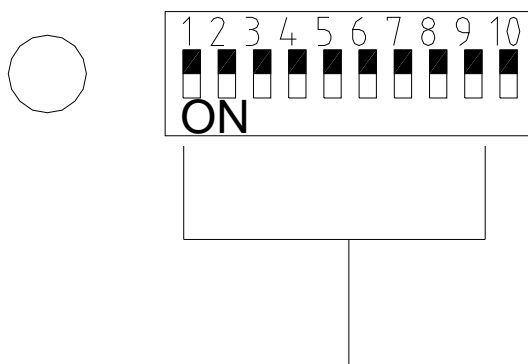

DIP SWITCH FOR ADDRESS SETTINGS

To set the start address, turn "ON" the proper switches, so that the sum of their weight gives the desired number. The weight of each switch is shown in the following table.

Switch ON	Weight
1	1
2	2
3	4
4	8
5	16
6	32
7	64
8	128
9	256

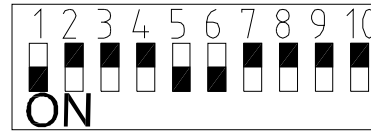

Example: start address 49 = switch ON 6 + 5 + 1 (32+16+1 = 49).

08 – AUTOMATIC MODE

The Colour Dance can function in a sound activated automatic mode. To set the master function, switch "ON" dip switch number 10 and adjust the microphone sensitivity. Leave all other switches "OFF".

If you wish to synchronise other slave projectors with the master unit, connect them with cable as described in section 06, with the first cable originating from the unit selected as master. Set the dip switch number 1 on the Slave units to "ON" (channel 1) and they will synchronise with the master unit. Leave all other switches "OFF".

09 – DMX CHANNELS

Channel	Function
1	Coloured gobo wheel
2	Mirror rotation
3	Lamp on/off

NOTE: There is a "Buffer Zone" on all DMX Channels, this means that the value at which a parameter starts is different when ascending (from 0 towards 255) than when descending (from 255 towards 0). The LOWER value shown is applicable when **descending only**. The HIGHER value when **ascending only**. If you are making a template for a controller you should use a value between the higher value and the lower value of the next parameter.

CHANNEL 1 – GOBO WHEEL

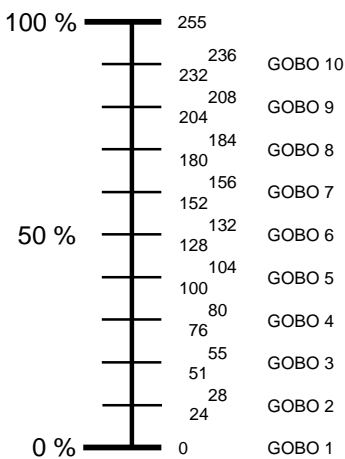

Control values for the **Gobo Wheel**, in DMX units.

CHANNEL 2 – MIRROR ROTATION

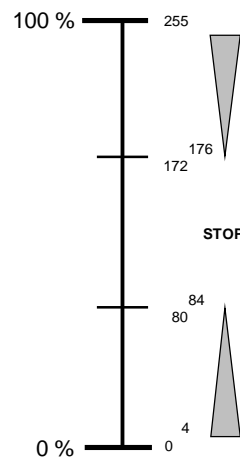

Control values for the **Mirror rotation**, in DMX units.

CHANNEL 3 – LAMP ON/OFF

DMX 0 (0%) = LAMP OFF, DMX 255 (100%) = LAMP ON

Control values for the **Lamp ON/OFF**, in DMX units.

10 – FOCUS

It is possible to move the lens for focusing the projector, simply twist the lens tube clockwise or anticlockwise to achieve focus.

11 – MAINTENANCE

If the projector's lens becomes damaged or broken it should be replaced.

If the lamp becomes damaged or deformed in any way it must be replaced.

If the light from the lamp appears dim this would normally indicate that it is reaching the end of its life and it should be changed at once, old lamps run to the extremity of their life can explode.

If the projector does not function, check the fuse by the power socket on the projector, it should only be replaced by a fuse of the same value as that marked beside the fuse holder.

The Colour Dance also has a thermal protection device that will switch off the projector in case of overheating, should this operate, check that the fan is not blocked, and if it is dirty clean it before switching on the projector again.

Check that the fan is operational, if not call a qualified technician.

12 – KEEPING THE PROJECTOR CLEAN

To ensure the reliability of the projector it should be kept clean. It is recommended that the fan should be cleaned every 15 days. The lens, mirror and dichroic colour filters should also be regularly cleaned to maintain an optimum light output. Do NOT use any type of solvent on the mirror or dichroic colour filters.

13 – TROUBLESHOOTING

PROBLEM	POSSIBLE SOLUTION
The projector does not start	Check the fuse by the power connector.
The lamp comes on but the projector does not respond to the controller	Check the digital start address (section 07) and check the wiring of the control cable (section 06).
The projector only functions intermittently	Check the fan is working and not dirty.
The projected image appears to have a halo	Check the lamp is installed correctly (section 03).
The beam appears dim	The lamp may be at the end of its life and should be replaced. Check the optics are clean.

Any other maintenance should only be performed by a qualified person.

14 – ELECTRICAL DIAGRAM

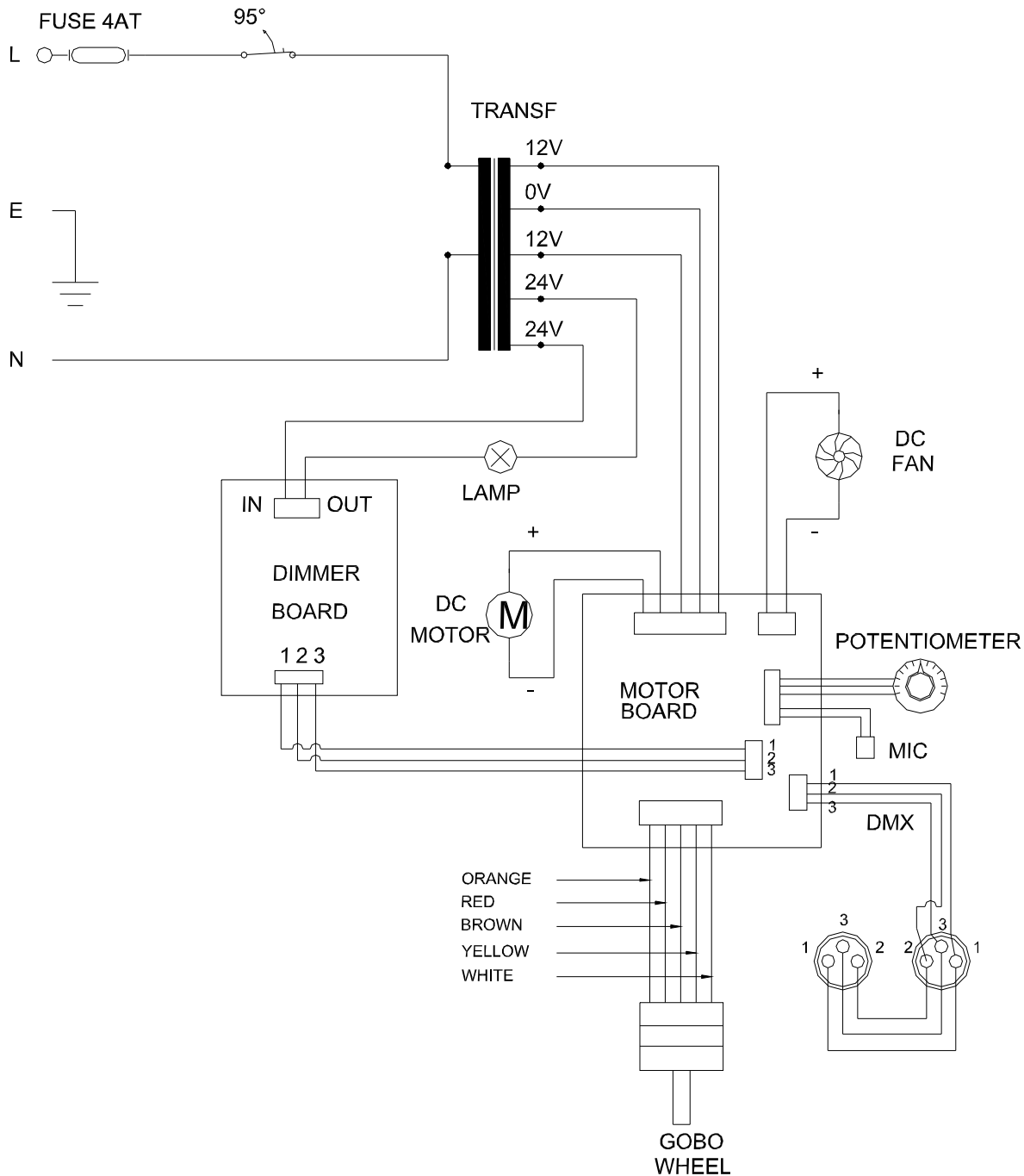

15 – TECHNICAL DATA

POWER SUPPLY:	230V 50Hz or 60Hz.
POWER CONSUMPTION:	280VA at 230V.
LAMP:	EVC/FGX 250W 24V Colour temperature 3200°K Socket G6,35 Life 300 hours (manufacturers rating).
GOBOS:	8 coloured gobos + white and blackout.
MOTORS:	1 stepper motor and 1 DC motor controlled by the internal microprocessor.
CONTROL:	Digital: DMX 512 standard (3 pin DMX Connectors) 3 control channels. Automatic: Sound activation via internal microphone with Master/Slave option.
HOUSING:	Plastic body. Easy access to lamp and main components. Protection: IP20.
DIMENSIONS:	520mm L x 270mm W x 280mm H (included bracket). Weight: 7kg.

